

Capacity Building Workshop in Angola

Huambo, 29 to 30 April 2009



REPÚBLICA DE ANGOLA
SECRETARIA DE ESTADO DAS ÁGUAS
DIRECÇÃO NACIONAL DE ÁGUAS



First Part

Presentation subject of the first part is a General Information about:

- 1) Water Sources
- 2) Water Lifting Systems
- 3) Handpump Types

Capacity Building Workshop in Angola

1) Water Sources

- a) Water Cycle
- b) Types of Water Sources
- c) Save Water Sources
- d) Pollution Prevention of Save Water Sources

Capacity Building Workshop in Angola

a) Water Cycle

Water Sources

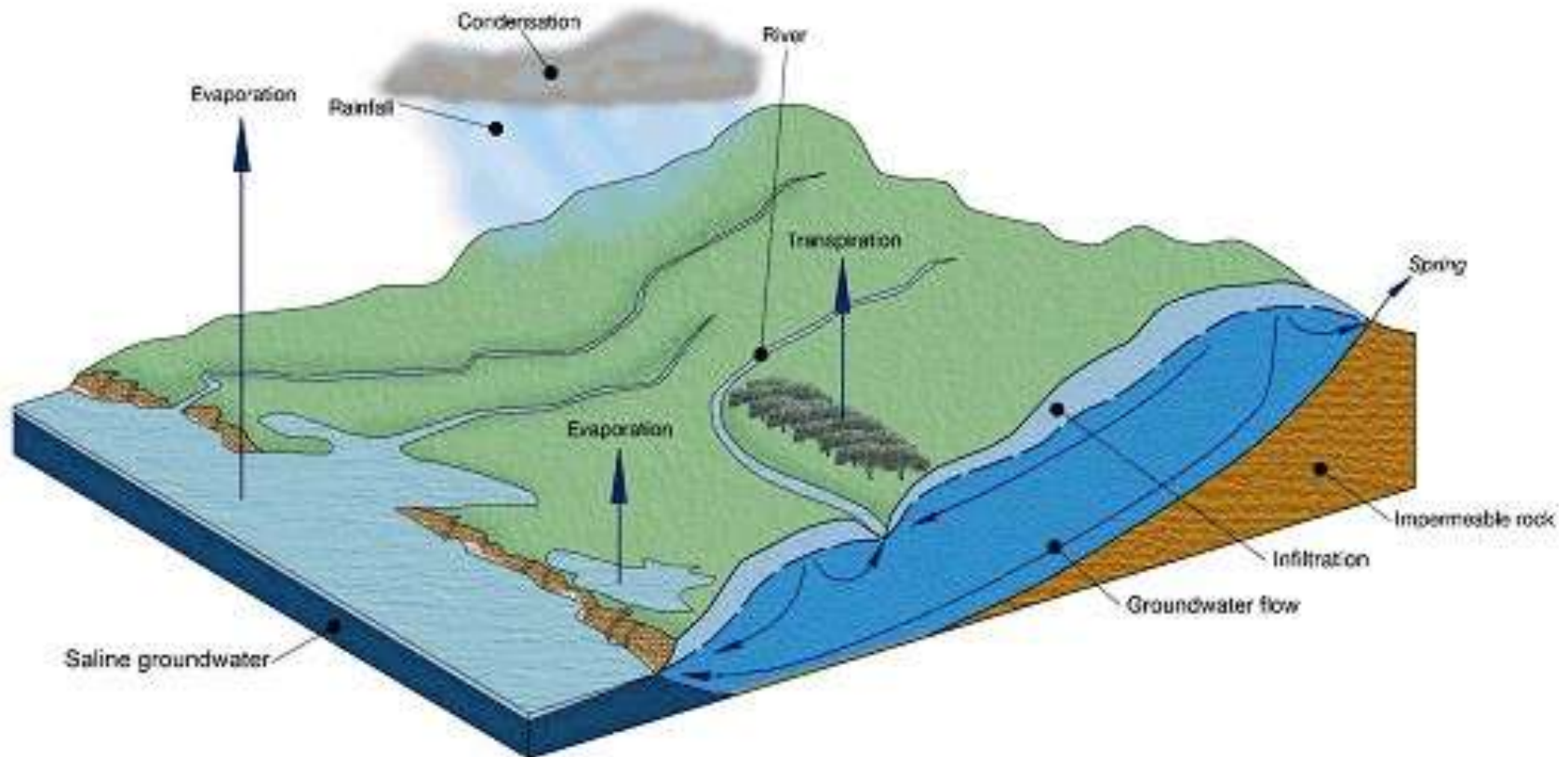

Capacity Building Workshop in Angola

b) Types of Water Sources

Water Sources

- Rainwater
- Surface Water
- Groundwater

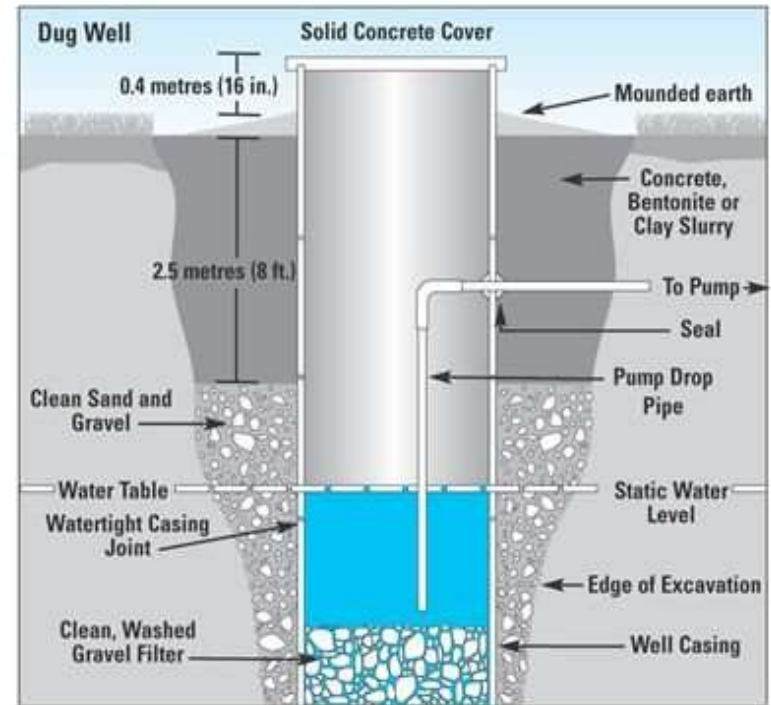

Capacity Building Workshop in Angola

c) Save Water Sources are:

Water Sources



Rainwater



Springwater

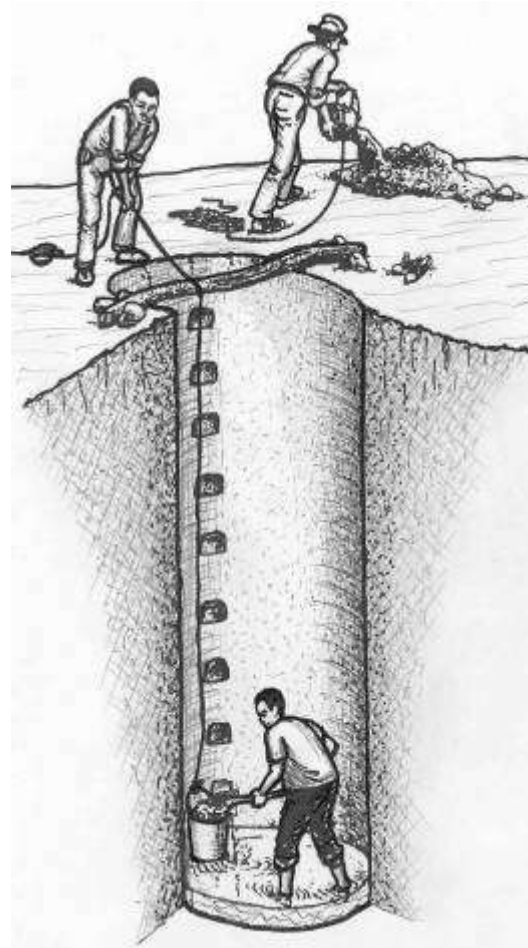

Groundwater drawn from a Dug-well or Borehole

The following water sources are regarded as save:

- Rainwater
- Springwater
- Groundwater

Capacity Building Workshop in Angola

d) Pollution Prevention of Groundwater Sources

Water Sources

- Covering open wells (use handpump)
- Regular cleaning of pump platform
- Repairing platform when cracked
- Fencing of platform
- Avoid pollution sources near the well

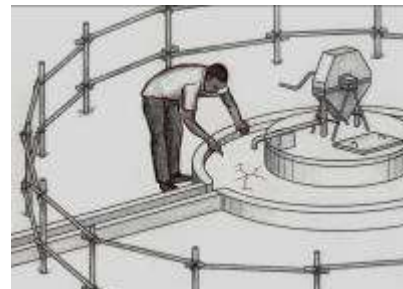
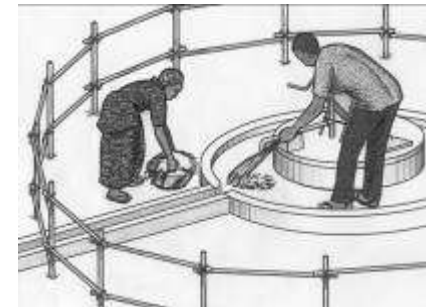
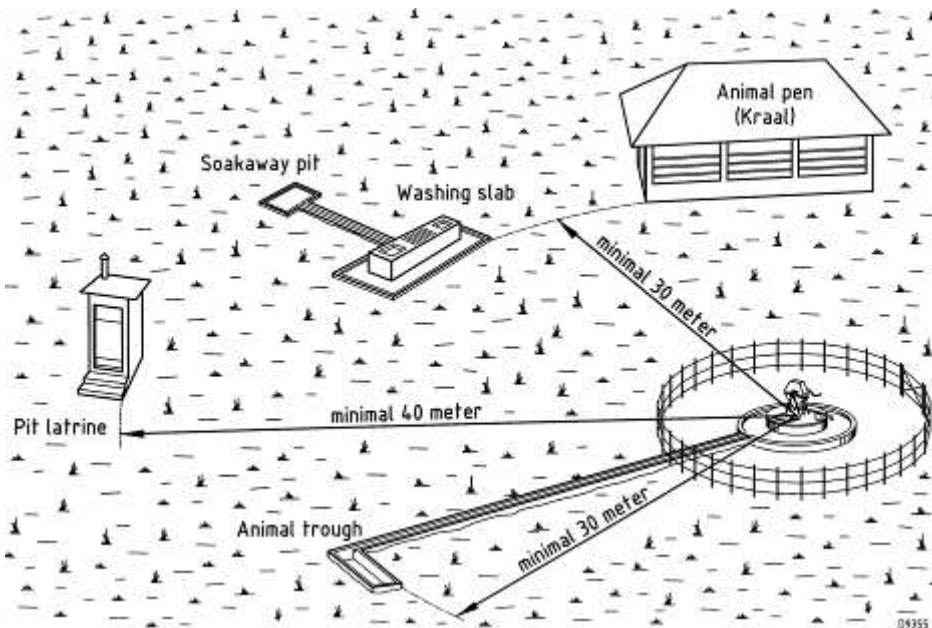

2) Water Lifting Systems

The dis-advantage with groundwater, it is not ready available for use, it must be lifted first to the groundlevel. There are several techniques for drawing water:

- a) Bucket with Rope**
- b) Handpumps**
- c) Mechanised Pumps**

Capacity Building Workshop in Angola

a) Bucket with Rope



No save way to draw water



Good example (Zimbabwe)

Water Lifting



The simplest way to lift water from a dug-well is the bucket with rope system.

However, contamination can easily take place if the well is not clean and protected by a cover.

Improved way to draw water (Mozambique)

Capacity Building Workshop in Angola

b) Handpumps

Water Lifting

Handpumps are small machines that need human power (mostly by hand or foot) for lifting the water from the well ground to the surface.

Regular maintenance of the handpump is the most important factor for a long life span of the pump, as indicated by the pump manufacturer.

Many handpump types are available, each of them designed for specific performance (i.e. deep or shallow wells, used by community or families, corrosive water, easy to repair etc.) depending on the place of use.

For Angola, the following handpumps have been standardised



**Volanta Pump
(Angola)**



**Afridev Pump
(Angola)**



**Vergnet Hydro-India
Pump (Angola)**

Capacity Building Workshop in Angola

c) Mechanised Pumps

Water Lifting

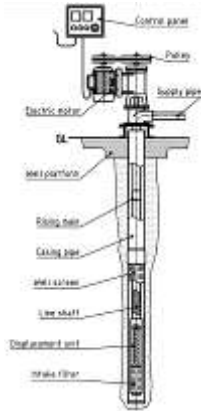

Grid powered pump

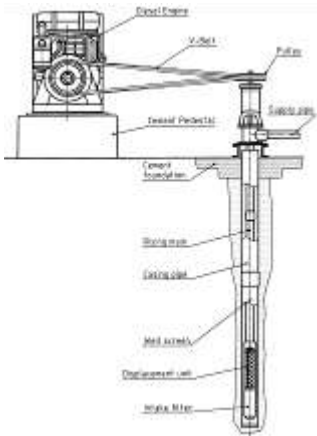

Diesel operated pump

Mechanized Pumps are:

- Diesel operated Pumps
- Grid powered Pumps
- Solar powered Pumps
- Wind driven Pumps
- Water driven Pumps

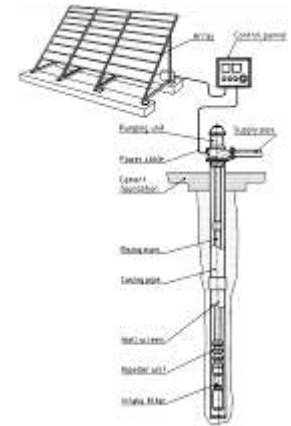

Solar powered pump



Wind driven pump

3) Handpump Types

The handpumps are kategorised according to their specific way of working:

- a) Reciprocating Pumps**
- b) Rotary Pumps**
- c) Displacement Pumps**

Capacity Building Workshop in Angola

a) Reciprocating Pumps

Handpump Types

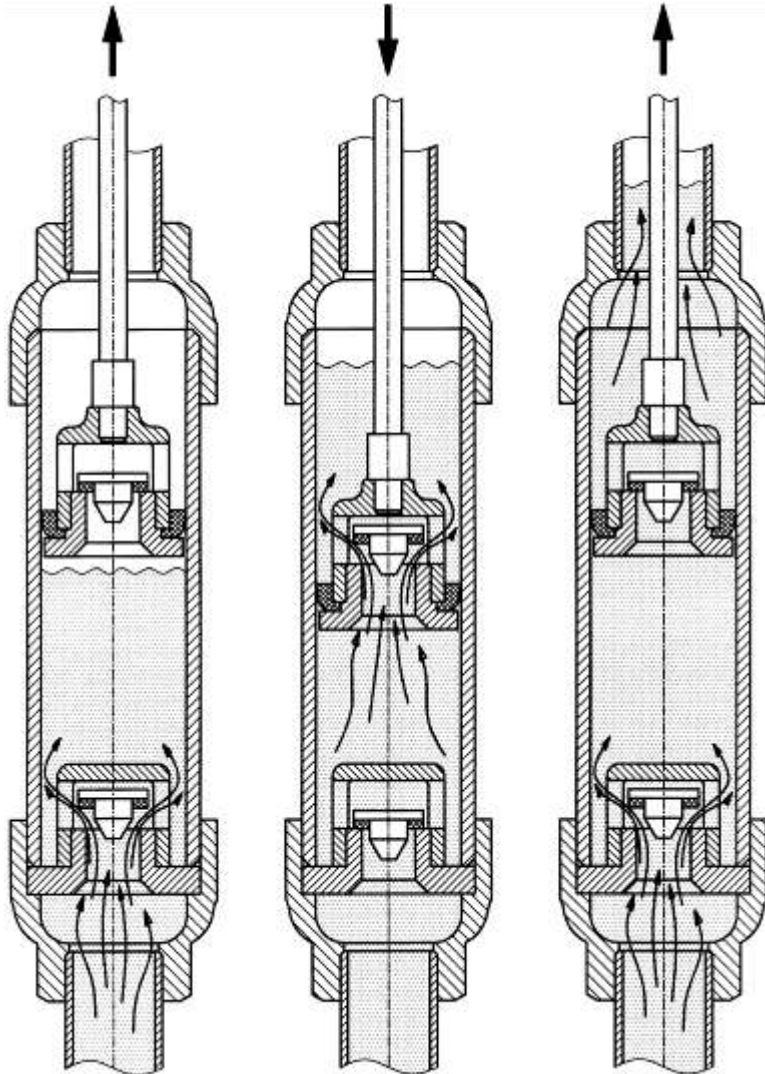

Most handpumps are reciprocating Pumps, in which a piston is moved up- and down inside a cylinder.

Reciprocating Pumps are:

- Suction Pumps
- Direct Action Pumps
- Lever Action Pumps
- Pumps with a Flywheel

Capacity Building Workshop in Angola

- Suction Pumps

Handpump Types

Reciprocating Pumps

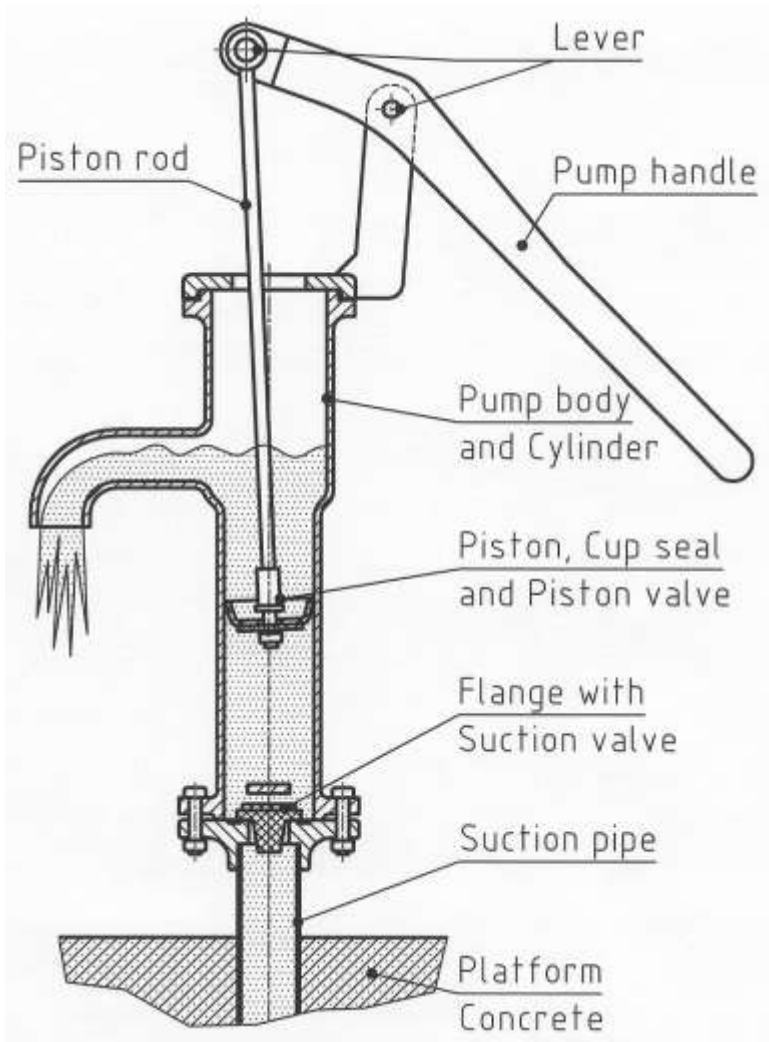

In a “suction” pump, the cylinder is above the water table. The water is “sucked” into the cylinder.

Suction pumps can be used to lift water up to about 7 to 8 meters. They need to be primed before they can be operated.

Suction Pumps are:

- India No. 6 Pump
- All Treadle Pumps

Capacity Building Workshop in Angola

- Examples

Handpump Types

Reciprocating Pumps

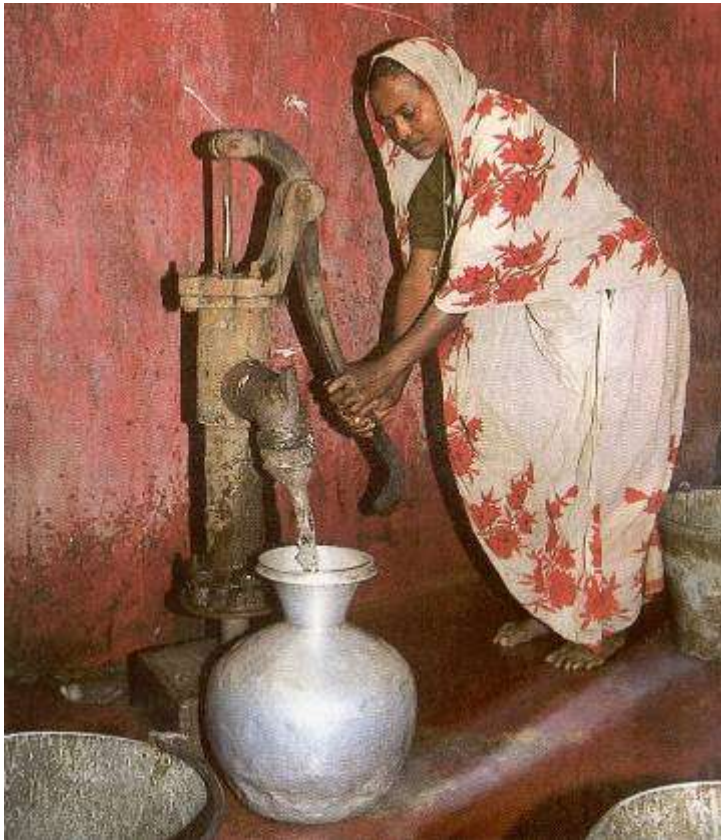

**India No. 6 Handpump
(Bangladesh)**



**Treadle Pump „Money Maker“
(Kenya)**

Capacity Building Workshop in Angola

- Direct Action Pump

Handpump Types

Reciprocating Pumps

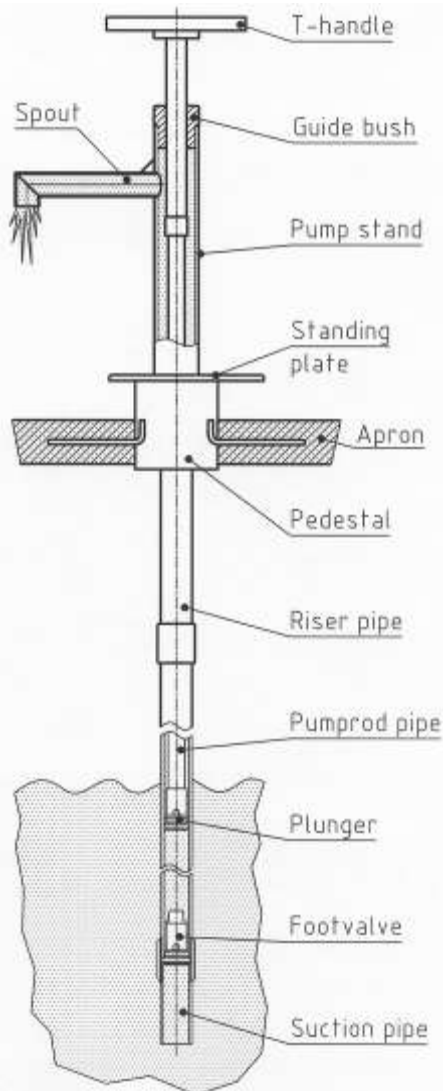

Direct action handpump have a T-handle directly connected to the pump rod and the piston.

Some of the pumps have pumprod pipes that are sealed airtight, thus buoyant which reduces the force needed on the up-stroke. They deliver water during up- and down-stroke.

Direct action pumps are mostly corrosion resistant, and very easy to handle by the communities.

Direct Action Pumps are:

- Nira & Malda Pumps
- Tara & Canzee Pump

Capacity Building Workshop in Angola

- Examples

Handpump Types

Reciprocating Pumps



**Nira Pump
(Mali)**



**Tara Pump
(India)**



**Malda Pump
(Madagascar)**



**Canzee Pump
(Madagascar)**

Capacity Building Workshop in Angola

- Lever Action Pump

Handpump Types

Reciprocating Pumps

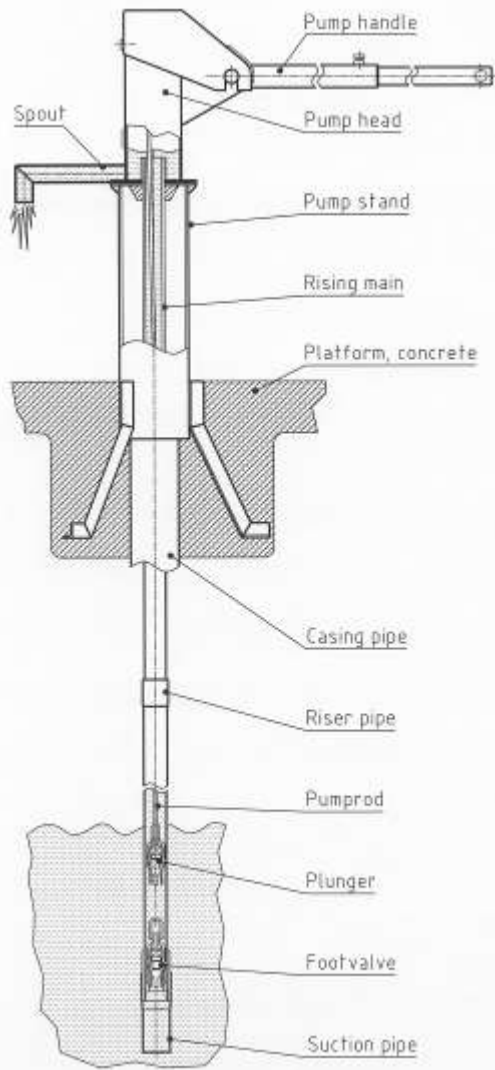

When the water has to be drawn from deeper levels pumping becomes heavier. To gain a mechanical advantage, levers are used to operate the pump.

For lever action pumps the terminology of “above ground” and “below ground” components is used. Above ground components are the pump stand, pump head and the handle, whereas the below ground components consist of the pump cylinder, the rising main pipe and the pumprods.

Lever Action Pumps are:

- Jibon, India Mark II & III Pumps,
- Walimi, Afridev & Bush Pumps.

Capacity Building Workshop in Angola

- Examples

Handpump Types

Reciprocating Pumps



**Jibon Pump
(Bangladesh)**



**Walimi Pump
(Tanzania)**



**India Mark II Pump
(Mali)**

Capacity Building Workshop in Angola

- Examples

Handpump Types

Reciprocating Pumps



**India Mark III Pump
(India)**



**Afridev Pump
(Mozambique)**



**Bush Pump
(Zimbabwe)**

Capacity Building Workshop in Angola

- Pumps with Flywheel

Handpump Types

Reciprocating Pumps

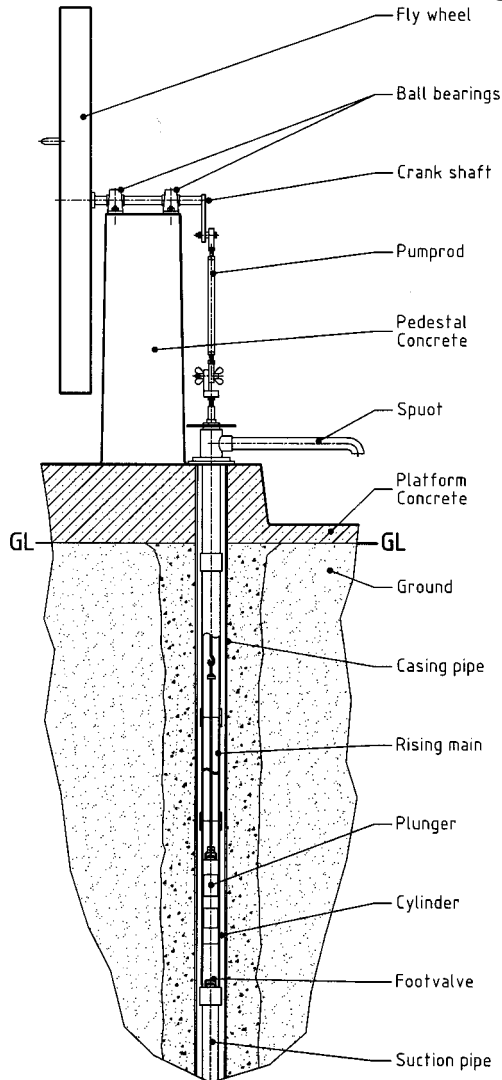

The Volanta Pump is driven by a large flywheel for medium and deep wells. It uses a retractable cylinder and a seal-less stainless steel piston. The stroke is adjustable to reduce the effort needed at deep installations. It is designed for heavy-duty use

Pumps with Flywheel are:

- Volanta Pumps
- Climax Pumps
- Duba Tropic Pumps

Capacity Building Workshop in Angola

- Example

Handpump Types

Reciprocating Pumps



**Volanta Pump
(Angola)**

Capacity Building Workshop in Angola

b) Rotary Pumps

Handpump Types

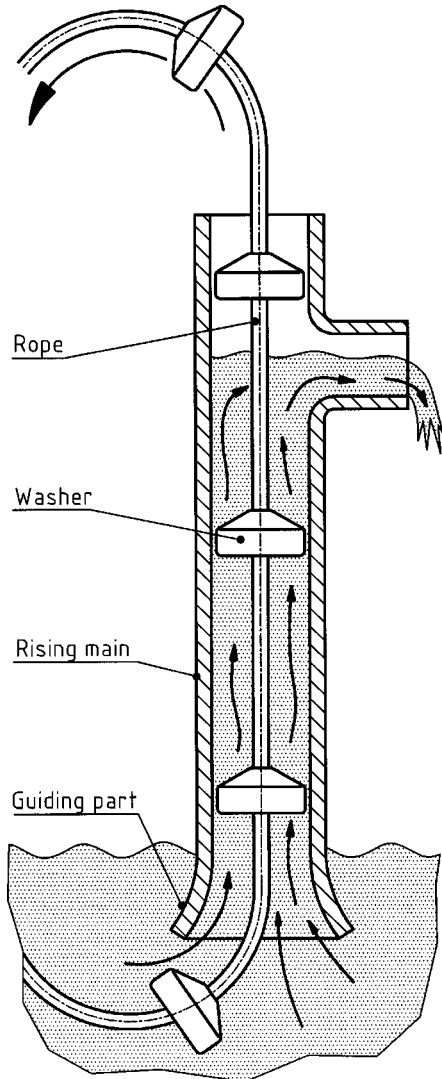

The Rope Pump is not defined with a specific design but a concept; small workshops produce different rope pump designs, adapted to their local conditions, sell the pumps directly to the users.

A pulley wheel (made of a car tyre) pulls the rope with the attached pistons through the rising main pipe. The pistons transport the water upwards to the spout.

Rotary Pumps are:

- **Rope Pumps** (they are built in Nicaragua, Madagascar, Mozambique and many other countries globally).

Capacity Building Workshop in Angola

- Examples

Handpump Types

Rotary Pumps



**Mecate Rope Pump
(Nicaragua)**



**Rope Pump
(Madagascar)**



**Rope Pump
(Mozambique)**

Capacity Building Workshop in Angola

c) Displacement Pumps

Handpump Types

Displacement Pumps are:

- Diaphragm Pumps
- Progressive Cavity Pumps

Capacity Building Workshop in Angola

- Diaphragm Pumps

Handpump Types

Displacement Pumps

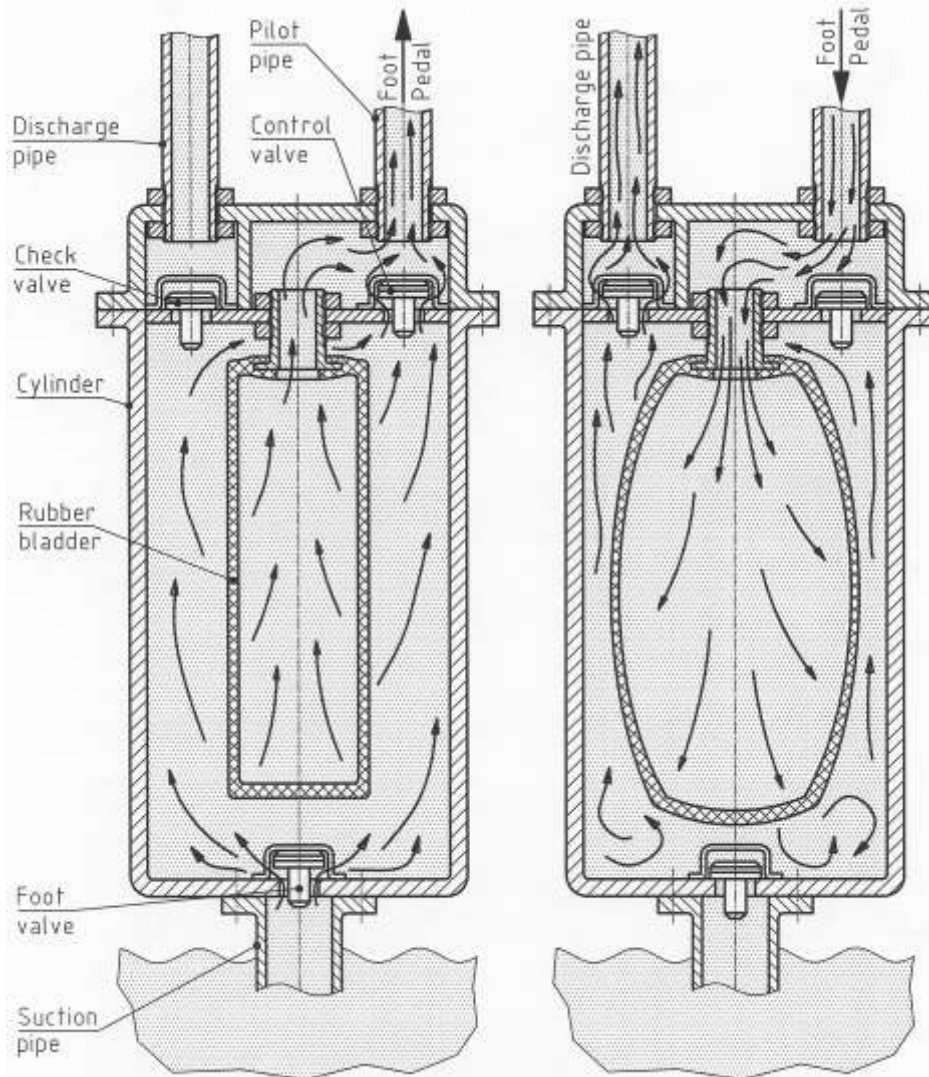

Diaphragm Pumps use a flexible diaphragm, which is expanded & contracted to displace water.

They have no heavy mechanical parts below ground.

The high quality diaphragms are costly and their efficiency is relatively low.

Diaphragm Pumps are:

- Vergnet Hydro HPV 60
- Vergnet Hydro-India

Capacity Building Workshop in Angola

- Examples

Handpump Types

Displacement Pumps



**Vergnet Hydro HPV-60
(Angola)**



**Vergnet Hydro-India
Pump (Angola)**

Capacity Building Workshop in Angola

- Progressive Cavity Pumps

Handpump Types

Displacement Pumps

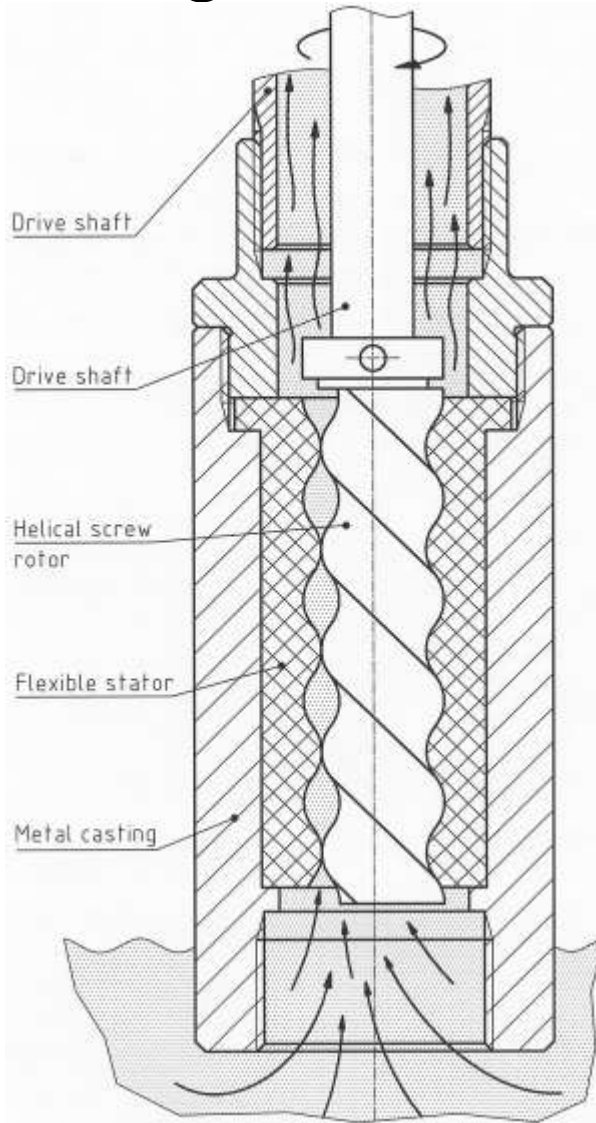

Progressive cavity pumps can be used in small diameter boreholes.

The pump has a rotor inserted into a rubber stator. When the rotor is turned the water will be pushed upwards and discharged into the rising main.

Progressive cavity pumps need to be driven at a relatively high speed; therefore, handpumps are often fitted with a gearbox (complicated & costly).

Progressive Cavity Pumps are:

- Orbit Pumps
- Mono Pumps

Capacity Building Workshop in Angola

- Examples

Handpump Types

Displacement Pumps



Orbit Pump
(Angola)



Mono Pump
(unknown)

Any Questions to the First Part?

